

# Aerobatic Paper Plane

This plane can perform circles & loops. The best paper is bond (thick) typing

paper. For a cute miniature plane, halve the measurements. Use bank paper (thin).

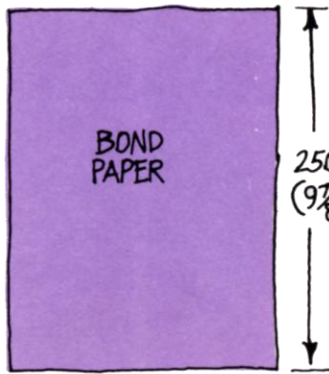

1. CUT PAPER TO SIZE

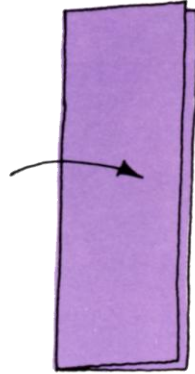

2. FOLD LONGWAYS IN THE CENTRE AND CREASE.

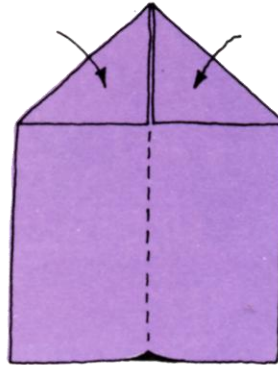

3. LAY PAPER WITH CREASE UPWARDS. FOLD CORNERS IN TO MEET AT CENTRE

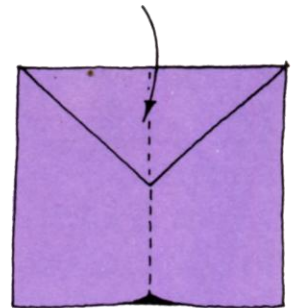

4. FOLD OVER AND CREASE.

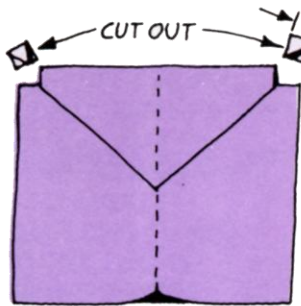

5. CUT SQUARES FROM CORNERS

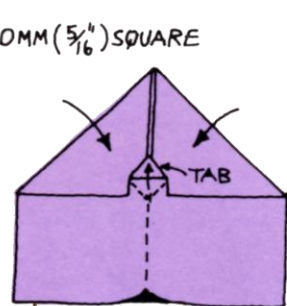

6. FOLD CORNERS IN. CREASE. FOLD TAB OVER.

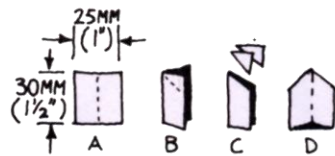

7. CUT A PIECE OF CARD (A) FROM A CEREAL BOX. FOLD IN THE CENTRE (B). CUT OFF CORNERS (C). OPEN OUT (D). THIS IS THE BALLAST OR NOSE WEIGHT.

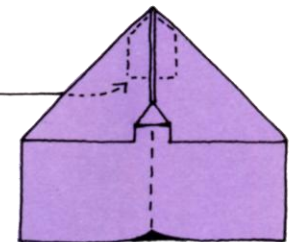

8. FIT BALLAST INSIDE NOSE POCKET.

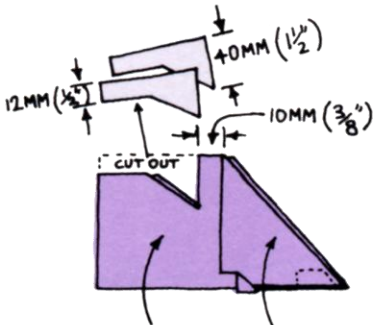

9. FOLD WINGS TOGETHER. CUT OUT SECTION SHOWN.

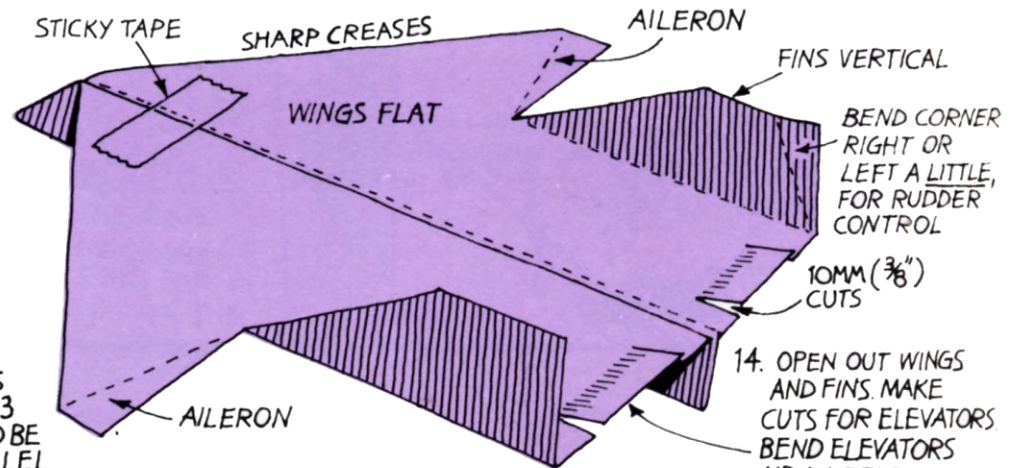

14. OPEN OUT WINGS AND FINS. MAKE CUTS FOR ELEVATORS. BEND ELEVATORS UP A LITTLE.

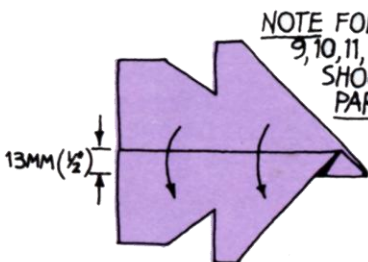

10. FOLD OVER ONE WING

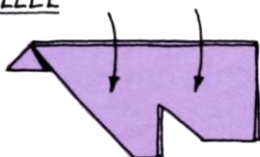

11. FOLD OVER OTHER WING

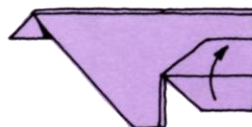

12. FOLD UP ONE FIN.

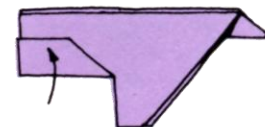

13. FOLD UP OTHER FIN.

# Aerobatics – tricky flying

To perform aerobatics with paper planes you need to practice different throws with different control settings.

Elevator control: Bend the elevators up for loops and turns. For long, level flight they should be fairly flat. For power dives with inverted pull-out, the elevators are bent down sharply.

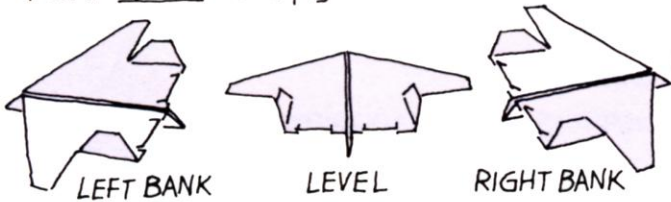

## Wing attitude (bank):

If the wings are banked when you throw, the plane will turn. If the left wing is low, it will turn left. If the right wing is low it will turn right.

Rudder: Another way to make it turn is to use the rudder. Bend it left (looking from behind) for a left hand turn. Bend it right for a right turn.

Ailerons: Bending one aileron up and the other down makes the plane roll. Small adjustments to the ailerons can correct unwanted turns or rolls.

## Direction and speed of throw:

Experiment with level, high and low throws. For some stunts you throw it straight up. Try fast and gentle throws.

